

Kingston Check Valves

# Kingston Model KCV234

Brass Vertical In Tank Check Valve



## Features:

- Precision machined C360 brass inlet
- Stainless steel spring
- 1/8" NPT Side Port
- Non-Return Air & Most Liquid Applications
- Maximum temperature 350°F
- Sizes: 3/8" NPT — 1-1/4" NPT
- Zinc coated snap ring for added corrosion resistance

Model	Inlet Size	Outlet Size	Cracking Pressure (PSI)	Dimension		Approx. Ship Wt.
				Height (A)	Hex (B)	
234-3-4	3/8"	1/2"	4	2-3/8"	7/8"	3.0 oz.
234-4-4	1/2"	1/2"	4	2-13/16"	1"	4.0 oz.
234-4-5	1/2"	3/4"	4	3-1/4"	1-1/8"	7.4 oz.
234-5-5	3/4"	3/4"	4	3-29/32"	1-3/16"	7.0 oz.
234-5-6	3/4"	1"	0.5	3-29/32"	1-5/16"	11.2 oz.
234-6-6	1"	1"	0.5	3-29/32"	1-1/2"	1 lb. 3.2 oz.
234-7-7	1-1/4"	1-1/4"	0.5	3-29/32"	1-7/8"	1 lb. 2.4 oz.

## Materials

No.	Part Name	Materials
1	Body	Brass (ASTM-B16)
2	Disc	Teflon—25% Glass Filled
3	Spring	Stainless Steel
4	Retaining Clip	Zinc Coated Carbon Steel
5	Spring Guide	Brass (ASTM-B16)

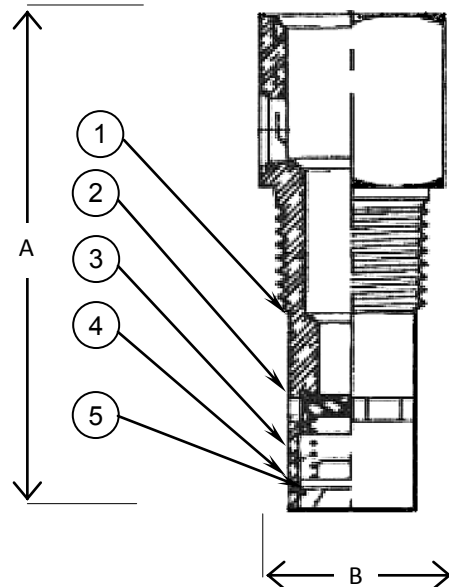

Storm Manufacturing Group  
 23201 Normandie Ave., Torrance CA 90501-5050  
 Toll Free: 866-628-8287 Fax: 800-997-0500 Direct: 310-326-8287

Copyright 2009 © Storm Manufacturing Group. All rights reserved. Product designs and specifications subject to change without notice. r.09a

# Kingston Model KCV234 Vertical In Tank Check Valve

## Flow Capacity Information

### Model KSV234 Flow Capacity

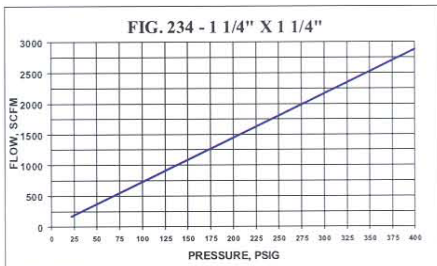
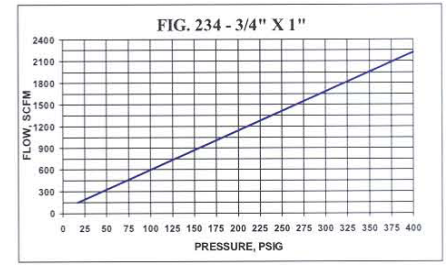
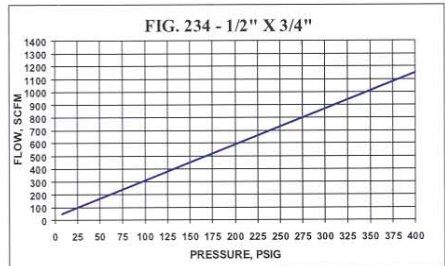
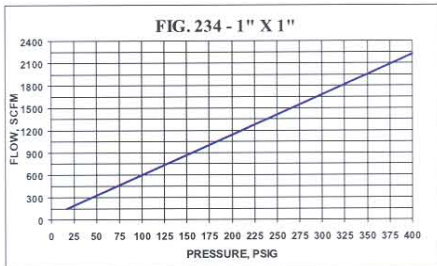
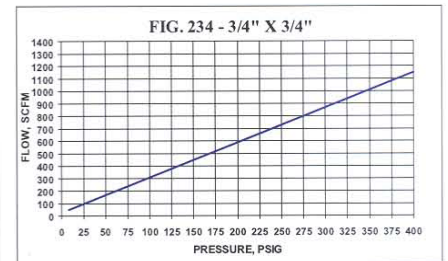
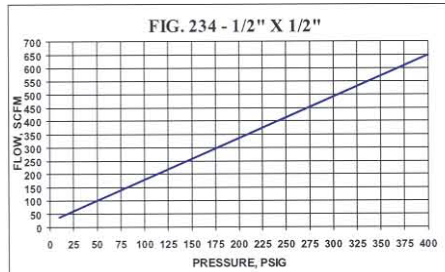
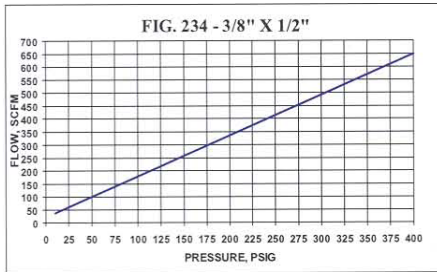

### Product Notes

All Kingston Check Valves are manufactured under a quality control system approved by the National Board of Boiler and Pressure Vessel Inspectors.

Final application design and integration of Kingston Products are the sole responsibility of the end user.

Storm Manufacturing reserves all rights. Product specifications and designs are subject to change without notice.

### Ordering Information

#### Kingston Vertical Check Valves Part Number Codes



#### Valve Model

- KCV234
- KCV237
- 226, 226A
- 227

#### Size

- 2 = 1/4" NPT
- 3 = 3/8" NPT
- 4 = 1/2" NPT
- 5 = 3/4" NPT
- 6 = 1" NPT



www.KingstonValves.com

**KINGSTON**

Storm Manufacturing Group  
 23201 Normandie Ave., Torrance CA 90501-5050  
 Toll Free: 866-628-8287 Fax: 800-997-0500 Direct: 310-326-8287