

Kingston Safety Valves

# Kingston Model KSV12 & KSV25

Low Profile ASME Code Section VIII "UV" Safety Valve  
High Flow



## Features:

- High Flow, Low Profile Safety Valve
- Compact, space saving design for small air systems
- Precision machined ASTM B16 Brass Construction
- Silicone disc for superior soft seat performance
- Stainless steel spring
- National Board Capacity Certified, "NB" Stamped
- ASME B&PVC Sect. VIII "UV" Air/Gas applications
- Maximum temperature 250°F
- Sizes: 1/8" NPT and 1/4" NPT

Model	Available Sizes	Orifice	Figure/Part No.	Height (A)	Hex (B)	Pressure Range PSIG	Approximate Ship Weight	Max Temp
KSV12	1/8" NPT	.250	KSV12-1-000	1.91"	11/16"	25-375	1.4 oz	250°F
KSV25	1/4" NPT		KSV25-2-000	2.1"			1.8 oz	

## Materials

No.	Part Name	Materials
1	Body	Brass (ASTM-B16)
2	Stem	Brass (ASTM-B16)
3	Adj. Screw	Brass (ASTM-B16)
4	Spring	Stainless Steel, Music Wire
5	Disc	Silicone
6	Pull Ring	Stainless Steel

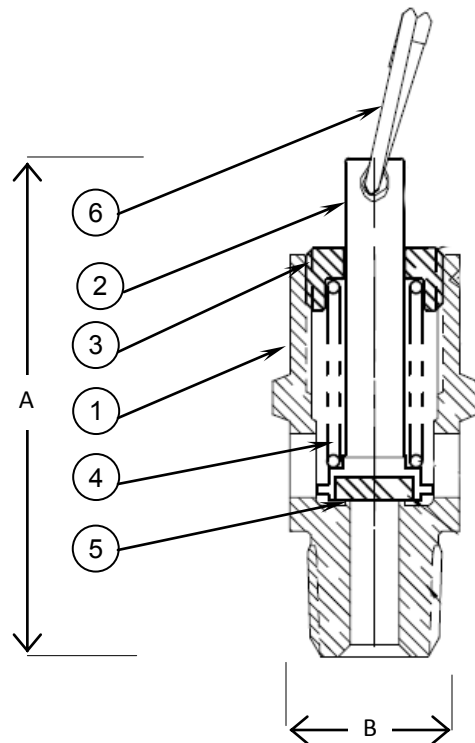

Storm Manufacturing Group  
23201 Normandie Ave., Torrance CA 90501-5050  
Toll Free: 866-628-8287 Fax: 800-997-0500 Direct: 310-326-8287

Copyright 2010 © Storm Manufacturing Group. All rights reserved. Product designs and specifications subject to change without notice. r.10a

# Kingston Model KSV12 & KSV25 Brass Low Profile High Flow Safety Valve

## Flow Capacity Information

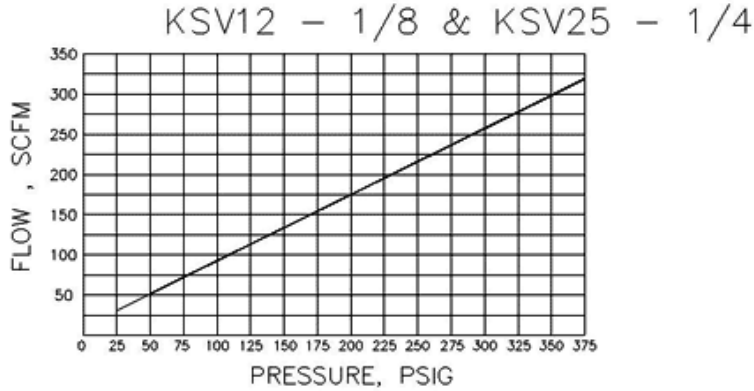

SET PRESSURE	STAMPED CFM		SET PRESSURE	STAMPED CFM	
psi	1/8"	1/4"	psi	1/8"	1/4"
25	29	29	205	165	165
30	33	33	210	169	169
35	36	36	215	173	173
40	40	40	220	177	177
45	44	44	225	181	181
50	48	48	230	184	184
55	52	52	235	188	188
60	55	55	240	192	192
65	59	59	245	196	196
70	63	63	250	200	200
75	67	67	255	203	203
80	71	71	260	207	207
85	74	74	265	211	211
90	78	78	270	215	215
95	82	82	275	219	219
100	86	86	280	222	222
105	90	90	285	226	226
110	93	93	290	230	230
115	97	97	295	234	234
120	101	101	300	238	238
125	105	105	305	241	241
130	109	109	310	245	245
135	112	112	315	249	249
140	116	116	320	253	253
145	120	120	325	257	257
150	124	124	330	260	260
155	128	128	335	264	264
160	131	131	340	268	268
165	135	135	345	272	272
170	139	139	350	276	276
175	143	143	355	279	279
180	146	146	360	283	283
185	150	150	365	287	287
190	154	154	370	291	291
195	158	158	375	294	294
200	162	162			

## Ordering Information

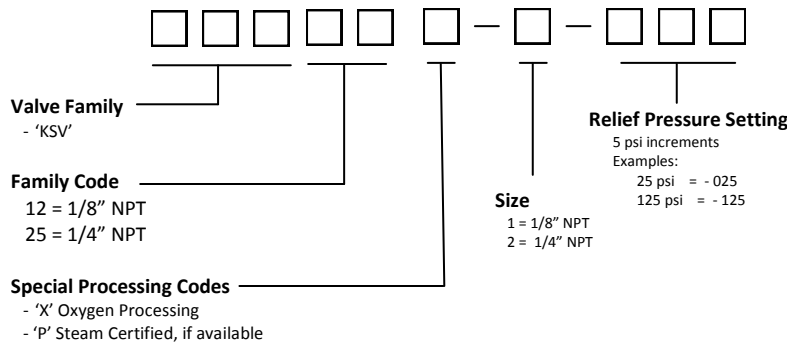

## Product Notes

All Kingston Safety Valves are manufactured under a quality control system accepted by the National Board of Boiler and Pressure Vessel Inspectors.

Code valves are capacity certified by the National Board, manufactured in accordance with ASME Code, set and sealed at the factory.

Set pressure can deviate from the marked by  $\pm 2$  psig at or below 70 psig set pressures and  $\pm 3\%$  psig above 70 psig.

Factory standard seat tightness for soft seat valves: no audible leakage at 10% below nameplate set. It is normal for spring-operated safety valves to exhibit leakage or simmer/warn, as the system operating pressure approaches the set pressure. For soft seat valves this typically occurs at pressures at or above 90% of nameplate set pressure.

At very low set pressures (20 psi and below), the ratio of the downward spring force as compared to the upward pressure force is very small. In these cases it may be impossible to achieve seat tightness.

Soft seat valves will typically provide a higher degree of seat tightness than metal, hard seats, Factory standard seat tightness does not ensure bubble-tight seal regardless of material.

Final application design and integration of Kingston Products are the sole responsibility of the end user.

Storm Manufacturing reserves all rights. Product specifications and designs are subject to change without notice.



Storm Manufacturing Group  
23201 Normandie Ave., Torrance CA 90501-5050  
Toll Free: 866-628-8287 Fax: 800-997-0500 Direct: 310-326-8287

Copyright 2010 © Storm Manufacturing Group. All rights reserved. Product designs and specifications subject to change without notice. r.10a