

Kingston Safety & Relief Valves

Kingston Model 103D

High Pressure Side Relief Outlet Valve



Features:

- Precision machined 303 Stainless Steel inlet
- Cast C844 Red Brass body
- Hard seat, 440C stainless steel ball
- Stainless steel spring
- NPT Side Outlet for direct connection
- Liquid and non-code air applications
- Maximum temperature 250°F
- Sizes: 1/4 NPT
- Set pressure range 5-1000 PSIG
- Every valve factory set and tested

Model	Sizes: inlet/Side	Orifice	Figure/Part No	Dimensions (inches)			Set Pressure Range PSIG	Approximate Ship Weight	Max Temp
				Height (A)	Hex (B)	Width (C)			
103D	1/4 NPT	.250	103D-2-000	3	3/4	1 1/4	5-1000	5 oz	250°F

Materials

No.	Part Name	Materials
1	Body	Cast Red Brass
2	Base	303 Stainless Steel
3	Cap	Brass
4	Stem Assembly	Stem, Ball
5	Adjusting Screw	Brass
6	Lock Nut	Brass
7	Spring	Stainless Steel
8	Gasket	Copper
9	Stem	Brass
11	Ball	Stainless Steel

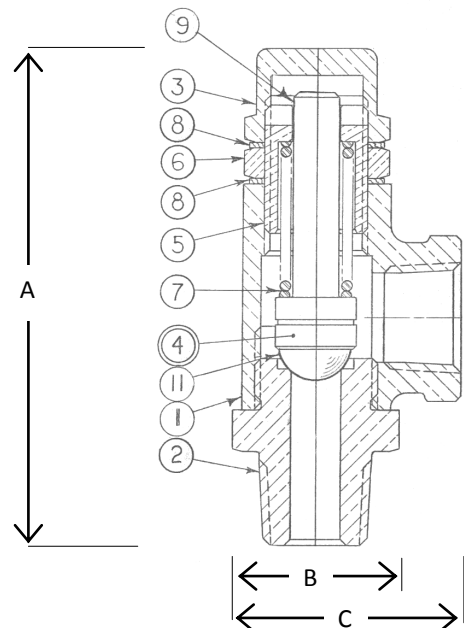

www.KingstonValves.com

Storm Manufacturing Group
 23201 Normandie Ave., Torrance CA 90501-5050
 Toll Free: 866-628-8287 Fax: 800-997-0500 Direct: 310-326-8287

Copyright 2009 © Storm Manufacturing Group. All rights reserved. Product designs and specifications subject to change without notice. r.09a

Kingston Model 103D Side Outlet Relief Valve

Flow Capacity Information

Model 103D-2 Flow Capacity

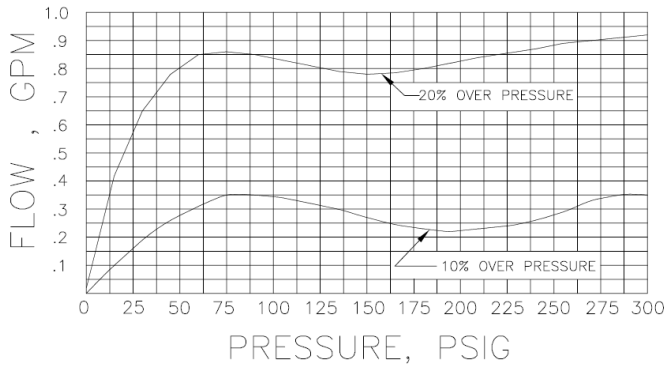

Model 103D-3 Flow Capacity

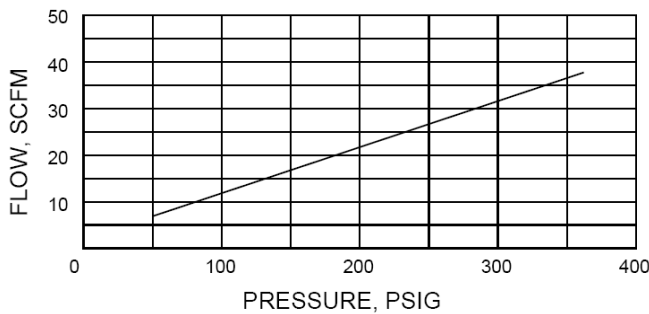
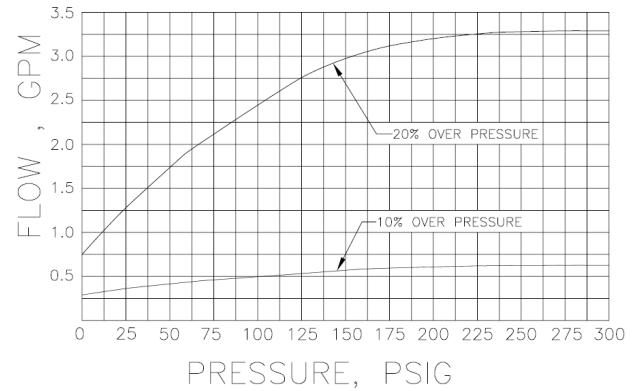

Product Notes

All Kingston Safety Valves are manufactured under a quality control system approved by the National Board of Boiler and Pressure Vessel Inspectors.

Coded valves are certified by the ASME and set and sealed at the factory.

Set pressure can deviate from the marked by ± 2 psi below 70 psi set pressures and $\pm 3\%$ at 70 psi and above.

Hard Seat Valves (metal to metal) are not inherently bubble tight. Kingston Valves conform to commercial seat tightness as defined in API Standard 527.

Final application design and integration of Kingston Products are the sole responsibility of the end user.

Storm Manufacturing reserves all rights. Product specifications and designs are subject to change without notice.

Ordering Information

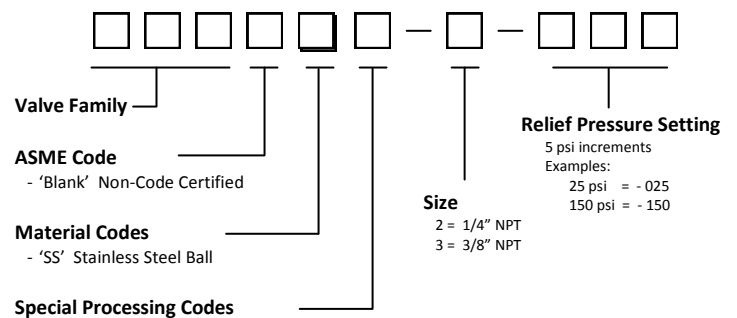

www.KingstonValves.com

Storm Manufacturing Group

23201 Normandie Ave., Torrance CA 90501-5050

Toll Free: 866-628-8287 Fax: 800-997-0500 Direct: 310-326-8287

Copyright 2009 © Storm Manufacturing Group. All rights reserved. Product designs and specifications subject to change without notice. r.09a